

OMAP Tools 

**PORTAUTENSILI STATICI
E MOTORIZZATI**

**STATIC AND DRIVEN
TOOLHOLDERS**

BMT 40

BMT 55

BMT 60

BIGLIA

INTEHNIKA.RU

0° DRILLING AND MILLING HEAD
TÊTE DE PERÇAGE - FRAISAGE 0°

0° BOHR -UND FRAESKOPF
UNIDAD PARA FORAR - FRESAR 0°

TESTA DI FORATURA - FRESATURA (0°)

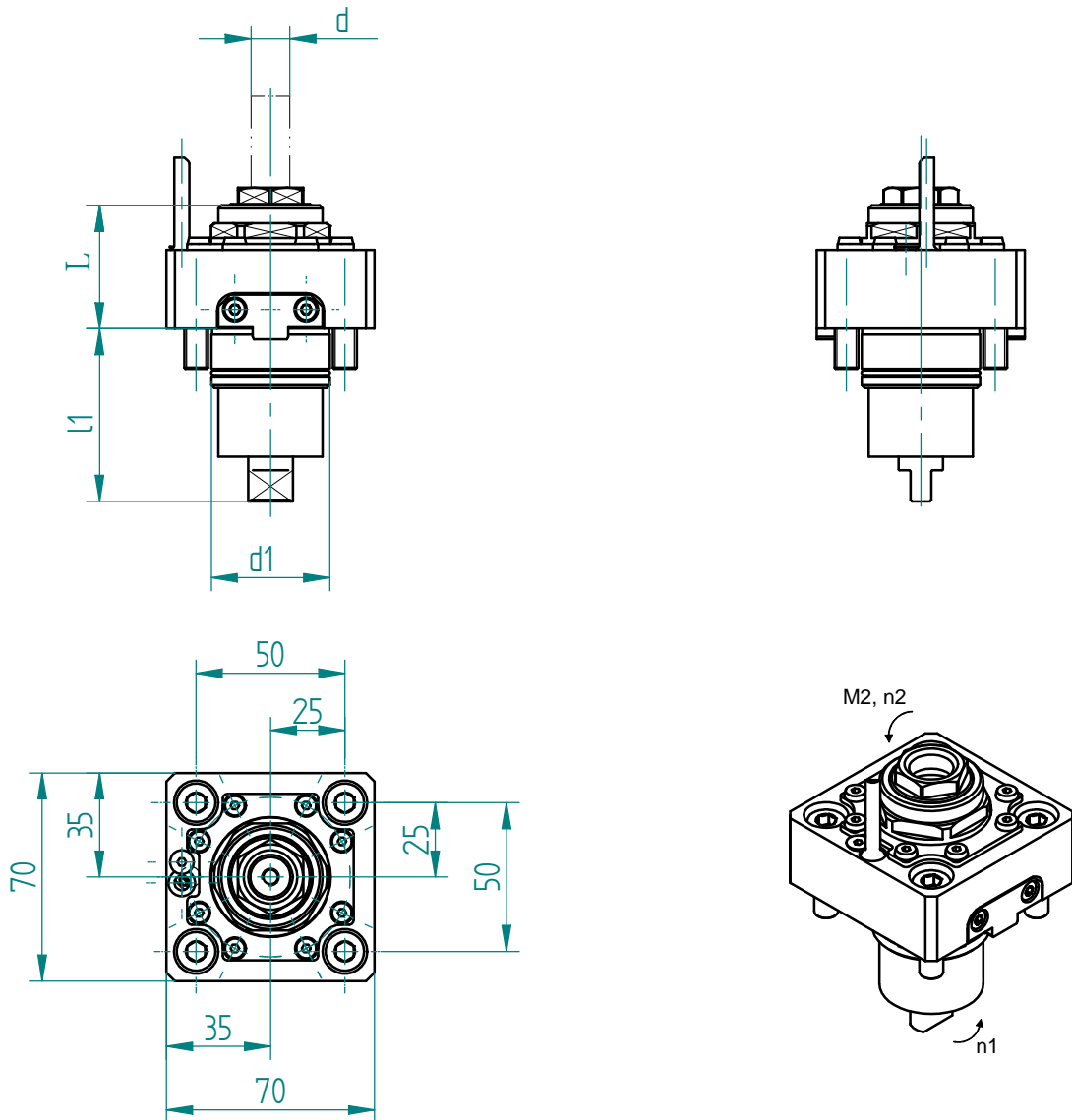

N. Cod.	Cod. OEM	Cod. Ext	Refrigerazione Coolant	d1	d	l1	L	n. Max	n1/n2	Nm
HE40BA13	T134-00128 C	153867	Ext.	40	1-13 ER 20	58	41,5	8500	1:1	32
RE40BA13	T134-00149	160167	External/Internal	40	1-13 ER 20	58	51	8500	1:1	32

90° DRILLING AND MILLING HEAD
TÊTE DE PERÇAGE - FRAISAGE 90°

90° BOHR -UND FRAESKOPF UNIDAD
PARA FORAR - FRESAR 90°

TESTA DI FORATURA - FRESATURA (90°)

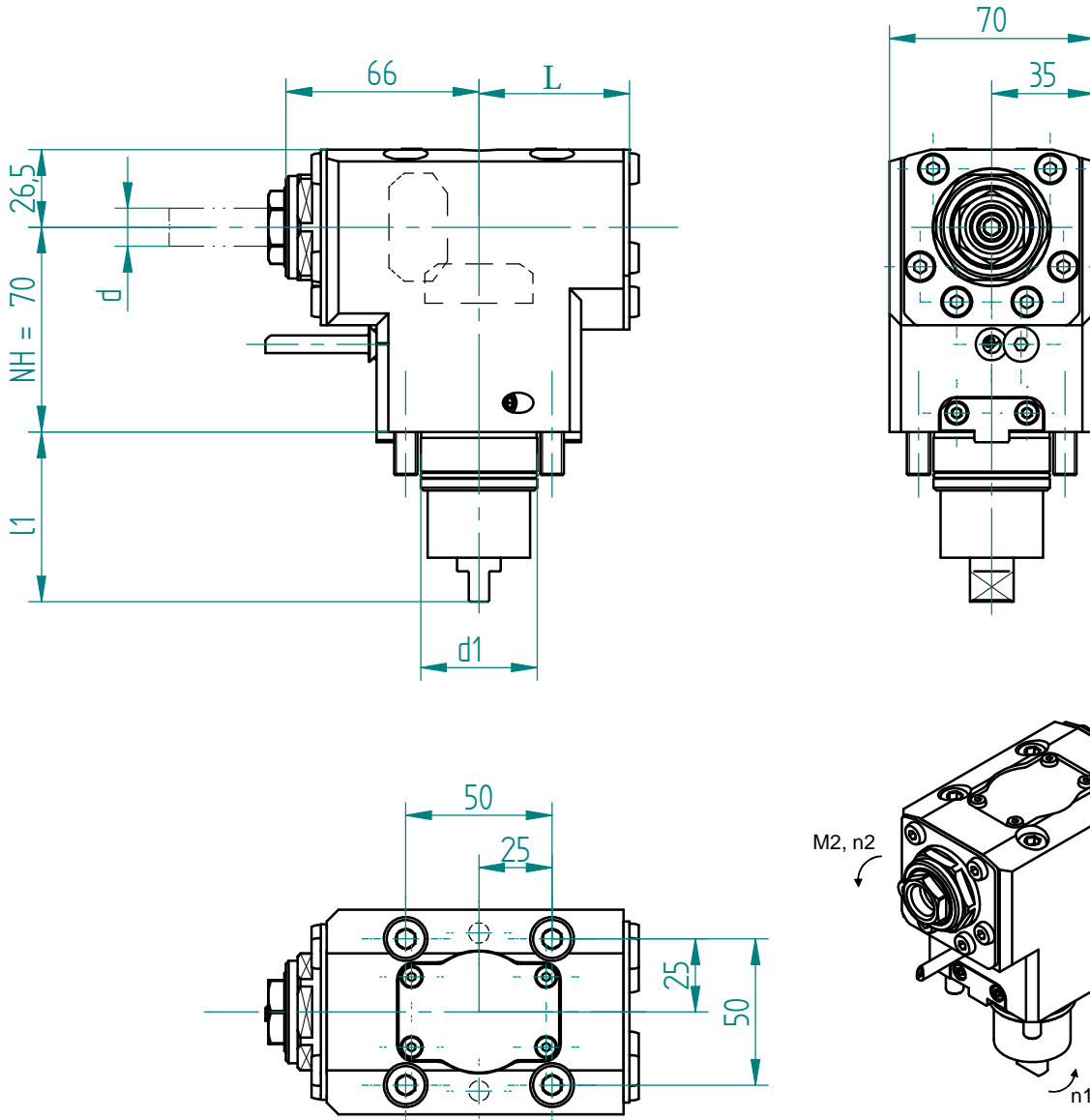

N. Cod.	Cod. OEM	Cod. Ext	Refrigerazione Coolant	d1	d	l1	L	n. Max	n1/n2	Nm
HE40BB13	T134-00129 C	153842	Ext.	40	1-13 ER20	58	51,5	8500	1:1	32
RE40BB13	T134-00150 C	155516	External/Internal	40	1-13 ER20	58	69,5	8500	1:1	32

0° DRILLING AND MILLING HEAD
TÊTE DE PERÇAGE - FRAISAGE 0°

0° BOHR-UND FRAESKOPF
UNIDAD PARA FORAR - FRESAR 0°

TESTA DI FORATURA - FRESATURA (0°)

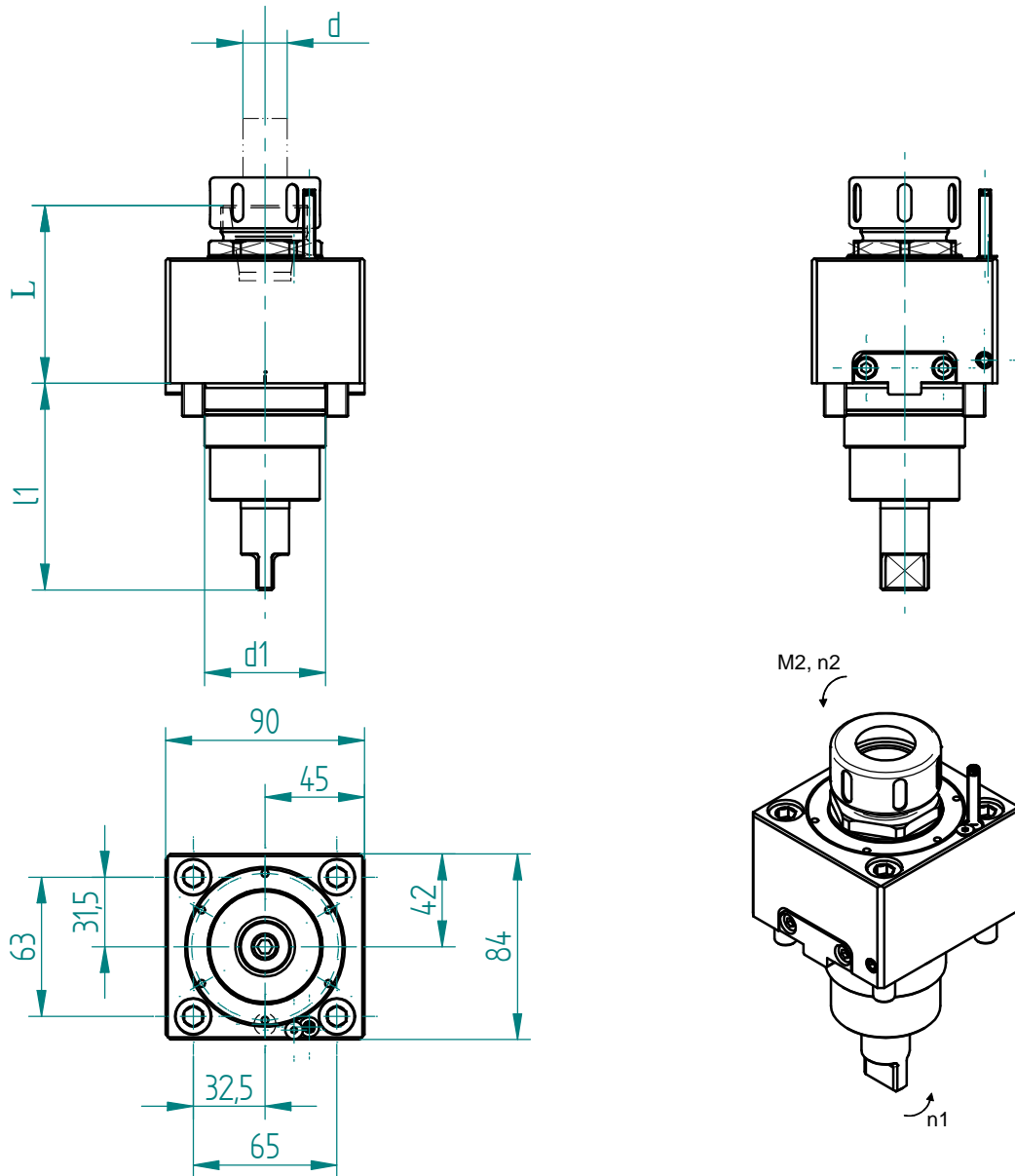

N. Cod.	Cod. OEM	Cod. Ext	Refrigerazione Coolant	d1	d	l1	L	n. Max	n1/n2	Nm
TE55BA20	T134-00089A	149829	Ext.	55	2-20 ER32	93,5	80,5	6000	1:1	70
RE55BA20	T134-00092A	149843	External/Internal	55	2-20 ER32	93,5	80,5	6000	1:1	70
RE55BA26	T134-00208	156405	External/Internal	55	3-26 ER40	93,5	87,5	6000	1:1	70

90° DRILLING AND MILLING HEAD
TÊTE DE PERÇAGE - FRAISAGE 90°

90° BOHR -UND FRAESKOPFUNITAD
PARA FORAR - FRESAR 90°

TESTA DI FORATURA - FRESATURA (90°)

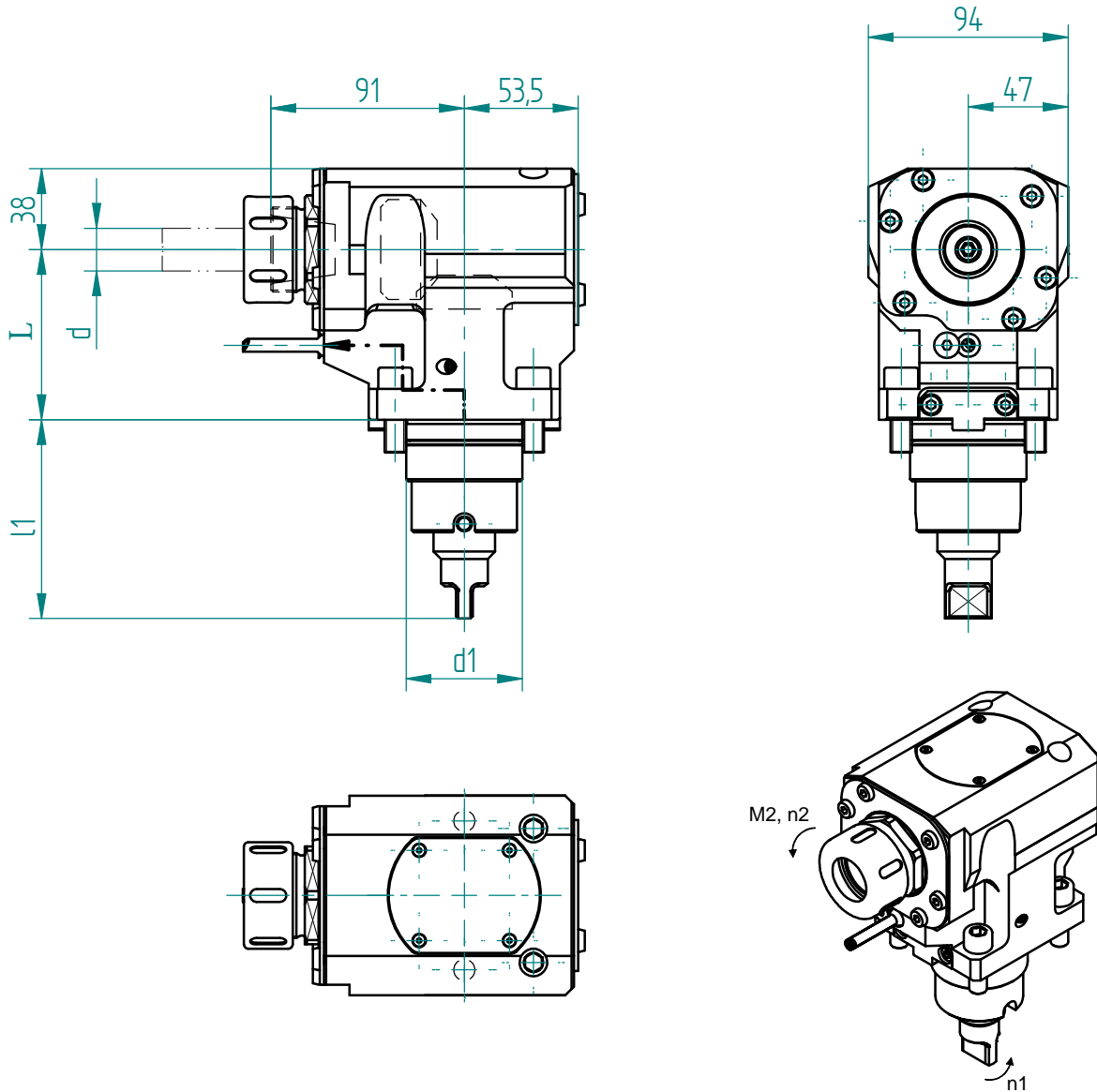

N. Cod.	Cod. OEM	Cod. Ext	Refrigerazione Coolant	d1	d	l1	L	n. Max	n1/n2	Nm
TE55BB20	T134-00210	153255	Ext.	55	2-20 ER32	93,5	80	6000	1:1	70
RE55BB20	T134-00211	153270	External/Internal	55	2-20 ER32	93,5	80	6000	1:1	70
RE55BB16	T134-00213	153330	External/Internal	55	2-16 ER25	93,5	80	6000	1:1	70
TE55BB20 100	T134-00178	149774	Ext.	55	2-20 ER32	93,5	100	6000	1:1	70
RE55BB20 100	T134-00088A	149862	External/Internal	55	2-20 ER32	93,5	100	6000	1:1	70

0° DRILLING AND MILLING HEAD
TÊTE DE PERÇAGE - FRAISAGE 0°

0° BOHR -UND FRAESKOPF
UNIDAD PARA FORAR - FRESAR 0°

TESTA DI FORATURA - FRESATURA (0°)

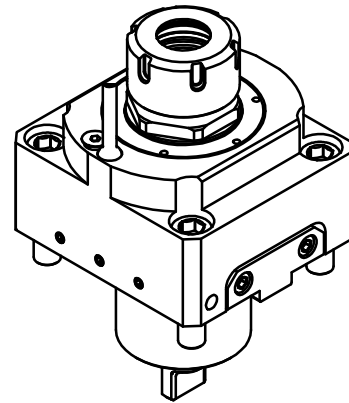
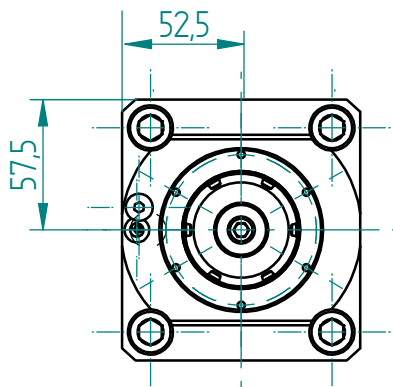
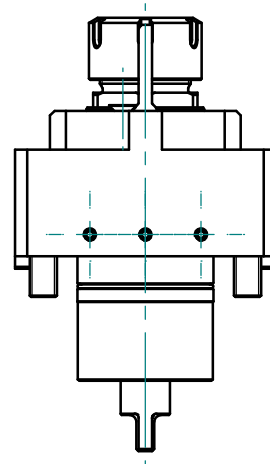
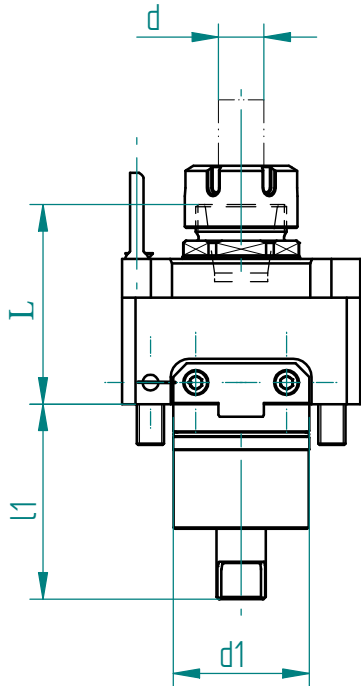

N. Cod.	Cod. OEM	Cod. Ext	Refrigerazione Coolant	d1	d	l1	L	n. Max	n1/n2	Nm
TE60BA20	T134-00139	148755	Ext.	60	2-20 ER32	86	83	6000	1:1	70
RE60BA20	T134-00190 IM 01	153061	External/Internal	60	2-20 ER32	86	88	6000	1:1	70
TE60BA26	T134-00140	148773	Ext.	60	3-26 ER40	86	83	6000	1:1	70
RE60BA26	T134-00191 IM 01	153118	External/Internal	60	3-26 ER40	86	95	6000	1:1	70

90° DRILLING AND MILLING HEAD
TÊTE DE PERÇAGE - FRAISAGE 90°

90° BOHR -UND FRAESKOPFUNITAD
PARA FORAR - FRESAR 90°

TESTA DI FORATURA - FRESATURA (90°)

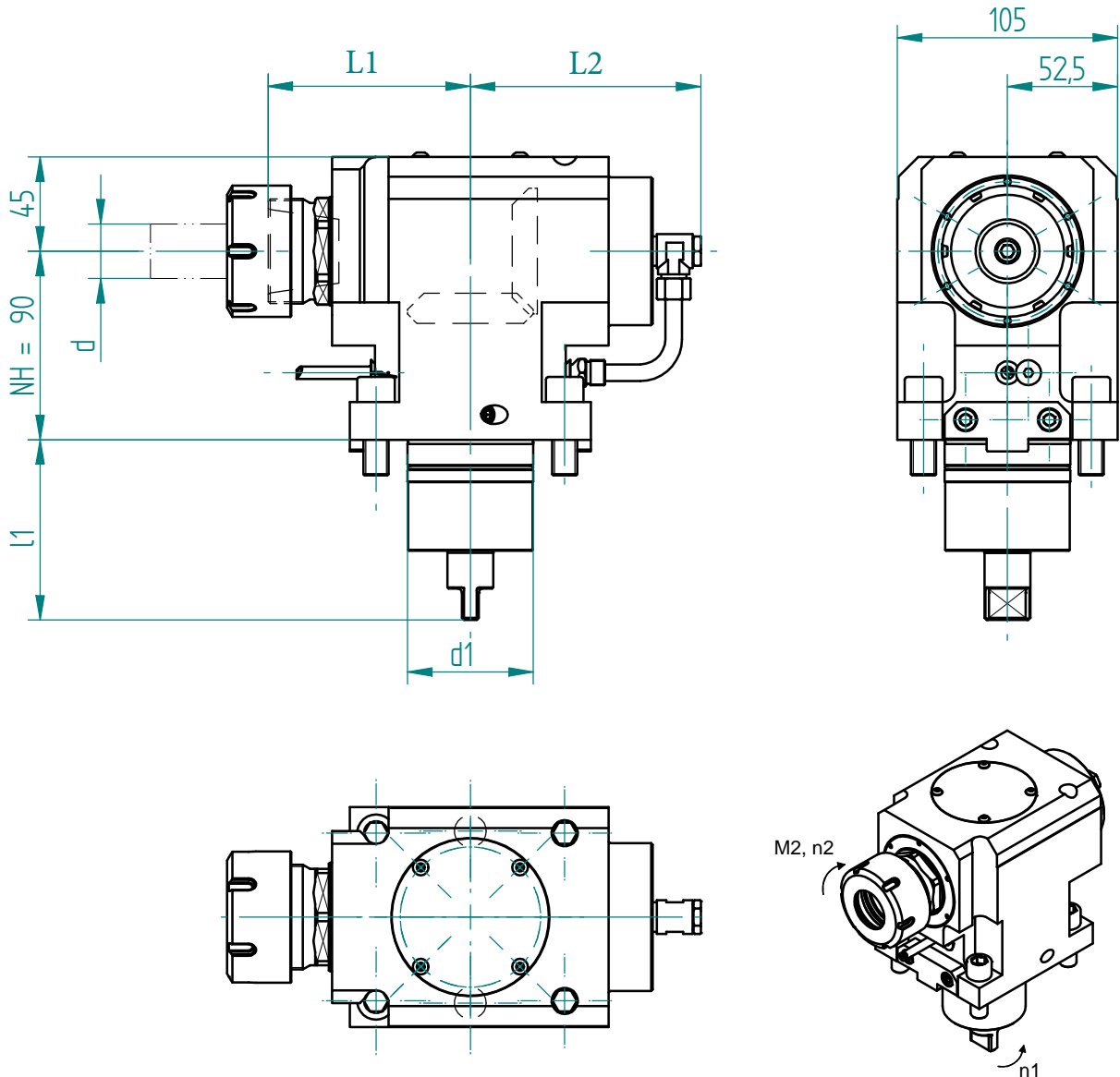

N. Cod.	Cod. OEM	Cod. Ext	Refrigerazione Coolant	d1	d	l1	L1	L2	n. Max	n1/n2	Nm
TE60BB20	T134-00141	148740	Ext.	60	2-20 ER32	86	90	66	6000	1:1	70
RE60BB20	T134-00192 IM 01	153119	External/Internal	60	2-20 ER32	86	90	110	6000	1:1	70
TE60BB26	T134-00142	148777	Ext.	60	3-26 ER40	86	96,5	66	6000	1:1	70
RE60BB26	T134-00193	153123	External/Internal	60	3-26 ER40	86	96,5	110	6000	1:1	70



OMAP TOOLS sas

Lungarno G. Reni, 38
52027 San Giovanni Valdarno (Ar)
Italy

CONTATTI - CONTACT

T. 0039 055 8349026
info@omaptools.com
www@omaptools.com