

OMAP Tools 

**PORTAUTENSILI
A CODA DI RONDINE**

**DOVETAIL
TOOLHOLDERS**

DIN 3425

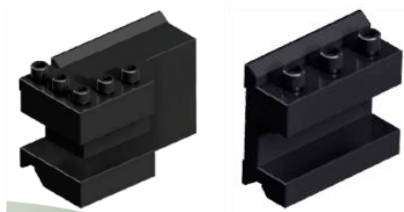

INTEHNIKA.RU



Omap Tools Sas lavora in questo settore dal 1970. Nata come officina meccanica in lavorazione per conto terzi è riuscita a rinnovare completamente la strategia aziendale con la produzione propria di Pinze e Mandrini Porta Pinze Din 69871 e Din 2080.

'70

OMAP TOOLS S.a.S. was founded in 1970. It was born as a machine shop working on short orders and was able to transform it self and its strategy, beginning with the manufacturing of brand name collet chucks, collets, and accessories for machine tools.

Negli anni 90, date le maggiori esigenze del cliente e grazie allo sviluppo tecnologico Omap Tools Sas è riuscita ad aumentare la sua gamma con la produzione dell'ultima generazione dei porta pinze HSK Din 69893 nelle diverse forme esistenti A-E-F e dei Moduli Rotanti.

'90

In the early 1990's due to technological upgrading OMAP TOOLS was able to satisfy growing customer needs by adding the new Rotary Driven Tools emerging on the market GOODWAY, DMG - MORI SEIKI, OKUMA MAZAK, DOSAAN, HAAS, TAKISAWA etc...

Sempre in quegli anni Omap Tools è tra le prime aziende in Italia a produrre moduli rotanti per torni a CNC.

'00

Da questo momento l'azienda, attraverso varie collaborazioni, crea una vasta gamma di motorizzati per le più importanti case produttive come GOODWAY, DMG - MORI SEIKI, OKUMA MAZAK, DOSAAN, HAAS, TAKISAWA ecc..



Nuovo management, ampliamento ufficio tecnico con utilizzo sistemi 3d.

'18

New management, increase technical department with 3D system,

CICLO PRODUTTIVO

La professionalità Omap tools nasce dal momento della ideazione del prodotto fino alla fase esecutiva. Durante l'ideazione e la progettazione dei prodotti, Omap tools si avvale dei più avanzati sistemi di progettazione come CAD3D per poi passare alla fase pre-esecutiva con processo di ingegnerizzazione CAD/CAM. Terminata la fase di elaborazione tecnica viene eseguito un prototipo per analizzare l'effettiva realizzazione.

Compiuto il primo prototipo viene creata una commessa, identificata attraverso un numero sequenziale, sulla quale vengono descritte dettagliatamente tutte le lavorazioni, dall'acquisto del materiale fino al collaudo, necessarie per arrivare al prodotto finale. Durante il ciclo produttivo ciascun articolo viene marcato con il numero della commessa e registrato da un sistema computerizzato.

PRODUCTION CICLE

OMAP TOOLS brings professional experience in every phase of production, from product conception through final testing. We use the latest CAD 3D systems for development and design and then CAD-CAM systems for product engineering. Using the technical drawings and engineering phases, OMAP TOOLS manufactures a prototype of every new product for analyzing feasibility in real-time applications.

As soon as the first prototype is approved, a job number is assigned. The job file describes the work process required for manufacturing the final product. It starts with material requirements and supply and continues through the final testing procedures. Each piece is marked with the job number and tracked from start to finish by a computerized system.

CONTROLLO QUALITÀ

Tale sistema permette di rintracciare in qualsiasi momento le varie fasi di lavorazione e anche tra 10 anni saremo in grado di sapere come e da chi sono stati eseguiti i nostri prodotti. Per poter garantire al 100% la qualità dei nostri articoli ciascun prodotto viene testato e collaudato attraverso macchine di controllo di alta qualità.

QUALITY CONTROL

This system registers the various manufacturing phases so that even after 10 years we are able to trace how and by whom any part was produced and any mistakes that might have been made. In order to guarantee 100% reliability each piece is subjected to a rigorous final testing, using high-tech testing equipment.



PORTAUTENSILI PER TORNI A CNC - DIN 3425

TOOLHOLDER FOR CNC LATHE - DIN 3425

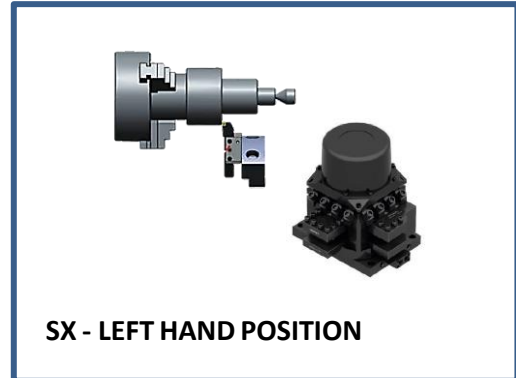
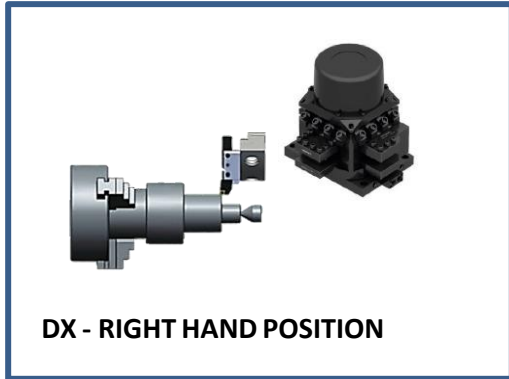

VERTICAL - RADIAL TOOL HOLDER - LEFT HAND

SX

FORMA A1

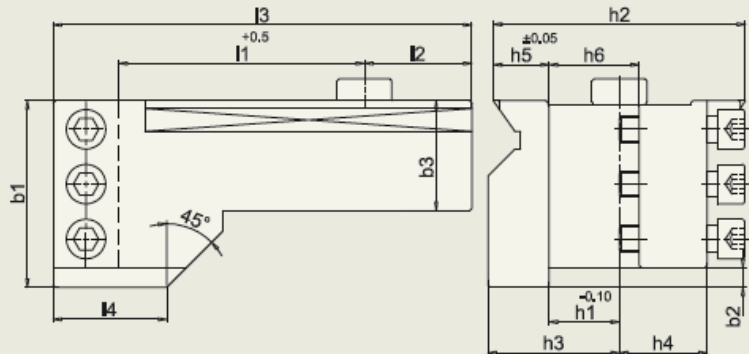

CODE	h2	h1	b1	b2	b3	h3	h4	h5	h6	I1	I2	I3	I4
VRTH-A1 72 25	72	25	63	6	40	43	26	16	29	49	39	110	45
VRTH-A1 90 25	90	25	72	9	40	50	35	20	34	73	39	138	45
VRTH-A1 115 32	115	32	85	9	50	60	40	25.5	41	112	49	191	50
VRTH-A1 140 40	140	40	110	12	60	78	57	30	53	115	59	209	55

Omap Tools di Frosinini Daniele & C sas

SEDE LEGALE: Via Montecarlo, 31 52027 S.GIOVANNI VALDARNO (AR) ITALY

SEDE OPERATIVA: Lungarno G. Reni, 38 52027 S.GIOVANNI VALDARNO (AR) ITALY - P.IVA – COD. FISC. 02307160511
ph 0039 055 8349026

info@omaptools.com

www.omaptools.it

INTEHNIKA.RU

VERTICAL - RADIAL TOOL HOLDER - RIGHT HAND **DX**

FORM A2

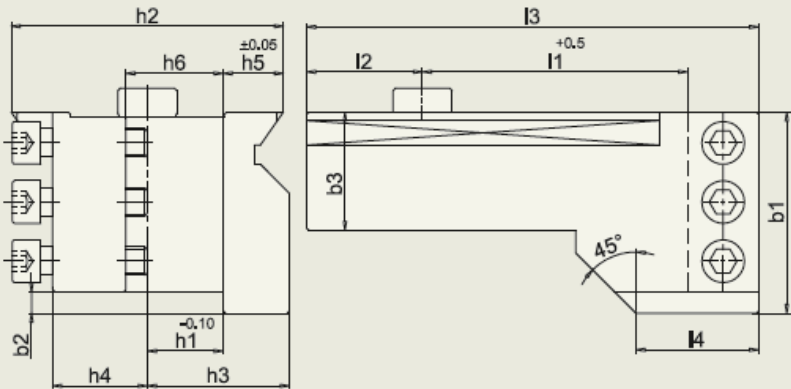

CODE	h2	h1	b1	b2	b3	h3	h4	h5	h6	I1	I2	I3	I4
VRTH-A2 72 25	72	25	63	6	40	43	26	16	29	49	39	110	45
VRTH-A2 90 25	90	25	72	9	40	50	35	20	34	73	39	138	45
VRTH-A2 115 32	115	32	85	9	50	60	40	25.5	41	112	49	191	50
VRTH-A2 140 40	140	40	110	12	60	78	57	30	53	115	59	209	55

VERTICAL - AXIAL TOOL HOLDER **SX**

FORM B1

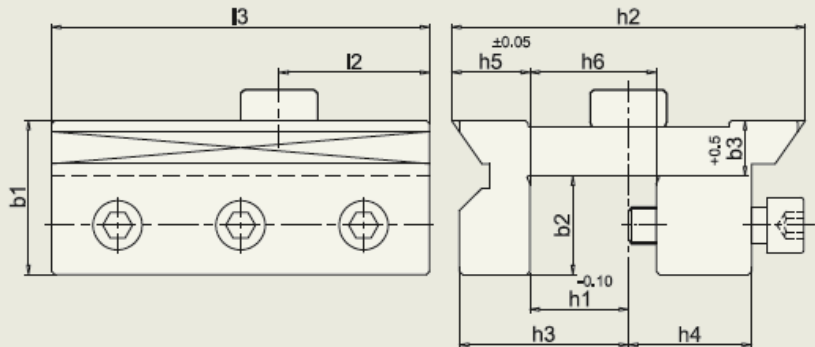

CODE	h2	h1	b1	b2	b3	h3	h4	h5	h6	I2	I3
VATH-B1 72 25	72	25	45	20	25	34	27	16	29	39	110
VATH-B1 90 25	90	25	50	25	25	42.5	35	20	34	39	118
VATH-B1 115 32	115	32	57	32	25	55	40	25.5	41	49	123
VATH-B1 140 40	140	40	70	40	30	67.5	57	30	53	59	160

Omap Tools di Frosinini Daniele & C sas

SEDE LEGALE: Via Montecarlo, 31 52027 S.GIOVANNI VALDARNO (AR) ITALY

SEDE OPERATIVA: Lungarno G. Reni, 38 52027 S.GIOVANNI VALDARNO (AR) ITALY - P.IVA – COD. FISC. 02307160511
ph 0039 055 8349026

info@omaptools.com

www.omaptools.it

INTEHNIKA.RU

VERTICAL - AXIAL TOOL HOLDER

DX

FORM B2

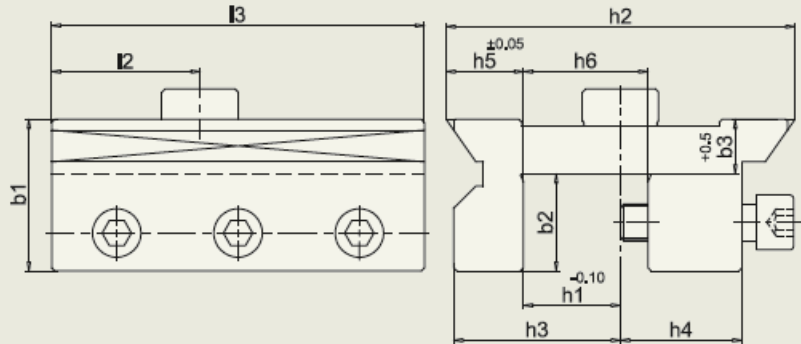

CODE	h2	h1	b1	b2	b3	h3	h4	h5	h6	l2	l3
VATH-B2 72 25	72	25	45	20	25	34	27	16	29	39	110
VATH-B2 90 25	90	25	50	25	25	42.5	35	20	34	39	118
VATH-B2 115 32	115	32	57	32	25	55	40	25.5	41	49	123
VATH-B2 140 40	140	40	70	40	30	67.5	57	30	53	59	160

VERTICAL - MULTIPLE TOOL HOLDER

SX

FORM C1

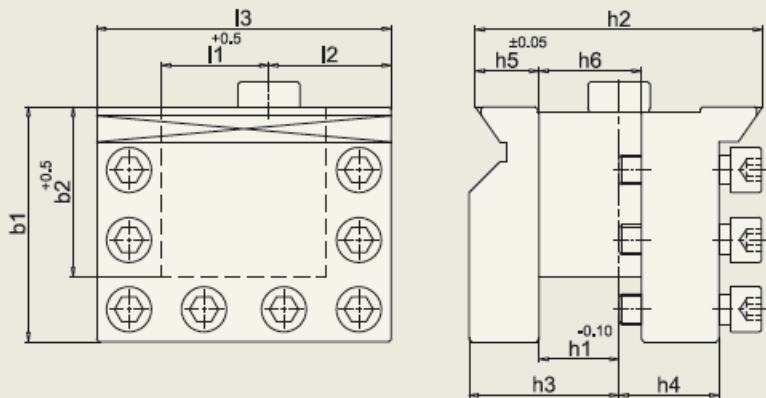

CODE	h2	h1	b1	b2	h3	h4	h5	h6	l1	l2	l3
VMTH-C1 72 25	72	25	81	59	43	27	16	29	37	39	98
VMTH-C1 90 25	90	25	88	62	50	35	20	34	43	39	108
VMTH-C1 115 32	115	32	94	68	60	40	25.5	41	43	49	118
VMTH-C1 140 40	140	40	115	83	78	57	30	53	53	59	144

Omap Tools di Frosinini Daniele & C sas

SEDE LEGALE: Via Montecarlo, 31 52027 S.GIOVANNI VALDARNO (AR) ITALY

SEDE OPERATIVA: Lungarno G. Reni, 38 52027 S.GIOVANNI VALDARNO (AR) ITALY - P.IVA – COD. FISC. 02307160511
ph 0039 055 8349026

info@omaptools.com

www.omaptools.it

INTEHNIKA.RU

VERTICAL - MULTIPLE TOOL HOLDER **DX**

FORM C2

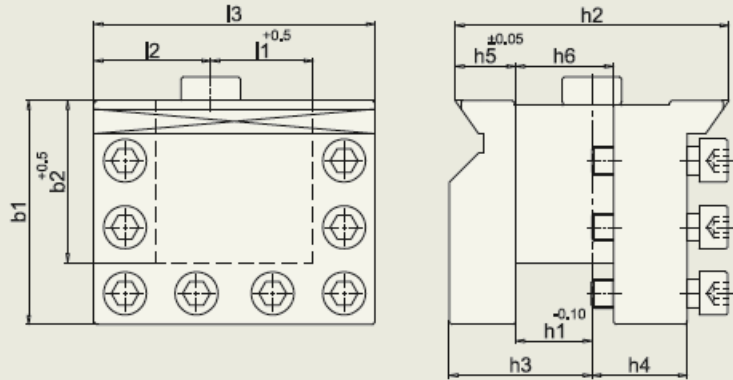

CODE	h2	h1	b1	b2	h3	h4	h5	h6	l1	l2	l3
VMTH-C2 72 25	72	25	81	59	43	27	16	29	37	39	98
VMTH-C2 90 25	90	25	88	62	50	35	20	34	43	39	108
VMTH-C2 115 32	115	32	94	68	60	40	25.5	41	43	49	118
VMTH-C2 140 40	140	40	115	83	78	57	30	53	53	59	144

VERTICAL - MULTIPLE TOOL HOLDER **SX - DX**

FORM C3

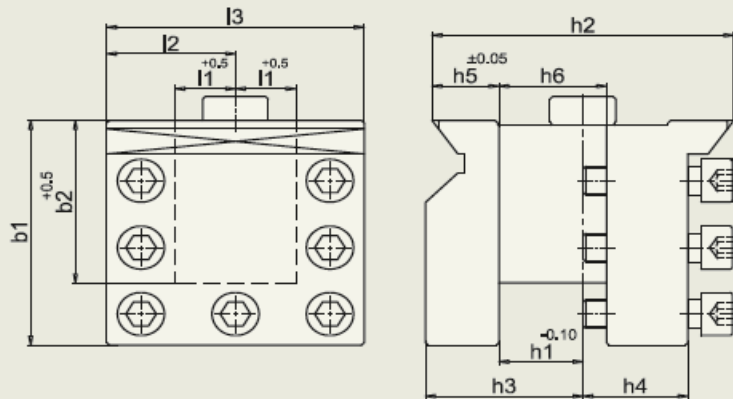

CODE	h2	h1	b1	b2	h3	h4	h5	h6	l1	l2	l3
VMTH-C3 72 25	72	25	81	59	43	27	16	29	17	39	78
VMTH-C3 90 25	90	25	88	62	50	35	20	34	23	49	98
VMTH-C3 115 32	115	32	94	68	60	40	25.5	41	23	49	98
VMTH-C3 140 40	140	40	115	83	78	57	30	53	27	59	118

Omap Tools di Frosinini Daniele & C sas

SEDE LEGALE: Via Montecarlo, 31 52027 S.GIOVANNI VALDARNO (AR) ITALY

SEDE OPERATIVA: Lungarno G. Reni, 38 52027 S.GIOVANNI VALDARNO (AR) ITALY - P.IVA – COD. FISC. 02307160511
ph 0039 055 8349026

info@omaptools.com

www.omaptools.it

INTEHNIKA.RU

VERTICAL - BORING TOOL HOLDER

SX

FORM D1

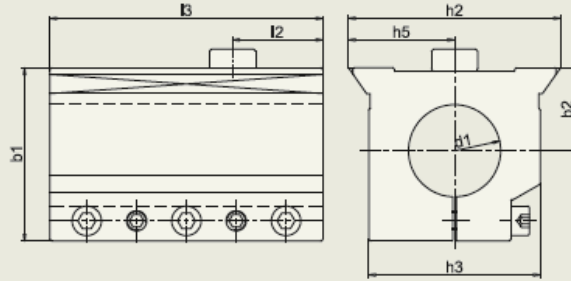

CODE	h2	d1	b1	b2	h3	h5	l2	l3		
VBTH-D1 72 40	72	40	76	35	±0.02	72	36	±0.02	39	110
VBTH-D1 72 50	72	50	80	40		72	36		39	110
VBTH-D1 90 50	90	50	94	45	±0.04	90	45	±0.04	39	138
VBTH-D1 90 60	90	60	100	50		90	45		39	138
VBTH-D1 115 50	115	50	94	45		93	57.5		49	148
VBTH-D1 115 60	115	60	100	50		93	57.5		49	148
VBTH-D1 115 80	115	80	120	60		115	57.5		49	148
VBTH-D1 140 60	140	60	110	60		115	70		59	178
VBTH-D1 140 80	140	80	125	60		115	70		59	178
VBTH-D1 140 100	140	100	145	70		140	70		59	178

VERTICAL - BORING TOOL HOLDER

DX

FORM D2

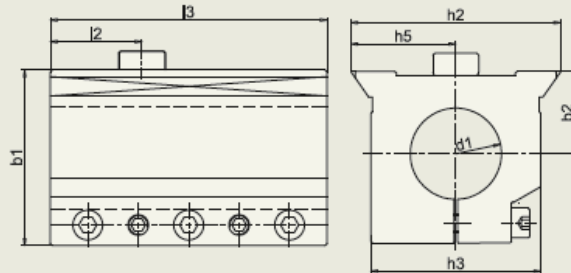

CODE	h2	d1	b1	b2	h3	h5	l2	l3		
VBTH-D2 72 40	72	40	76	35	±0.02	72	36	±0.02	39	110
VBTH-D2 72 50	72	50	80	40		72	36		39	110
VBTH-D2 90 50	90	50	94	45	±0.04	90	45	±0.04	39	138
VBTH-D2 90 60	90	60	100	50		90	45		39	138
VBTH-D2 115 50	115	50	94	45		93	57.5		49	148
VBTH-D2 115 60	115	60	100	50		93	57.5		49	148
VBTH-D2 115 80	115	80	120	60		115	57.5		49	148
VBTH-D2 140 60	140	60	110	60		115	70		59	178
VBTH-D2 140 80	140	80	125	60		115	70		59	178
VBTH-D2 140 100	140	100	145	70		140	70		59	178

Omap Tools di Frosinini Daniele & C sas

SEDE LEGALE: Via Montecarlo, 31 52027 S.GIOVANNI VALDARNO (AR) ITALY

SEDE OPERATIVA: Lungarno G. Reni, 38 52027 S.GIOVANNI VALDARNO (AR) ITALY - P.IVA – COD. FISC. 02307160511
ph 0039 055 8349026

info@omaptools.com

www.omaptools.it

INTEHNIKA.RU

VERTICAL - BORING TOOL HOLDER

SX - DX

FORM D3

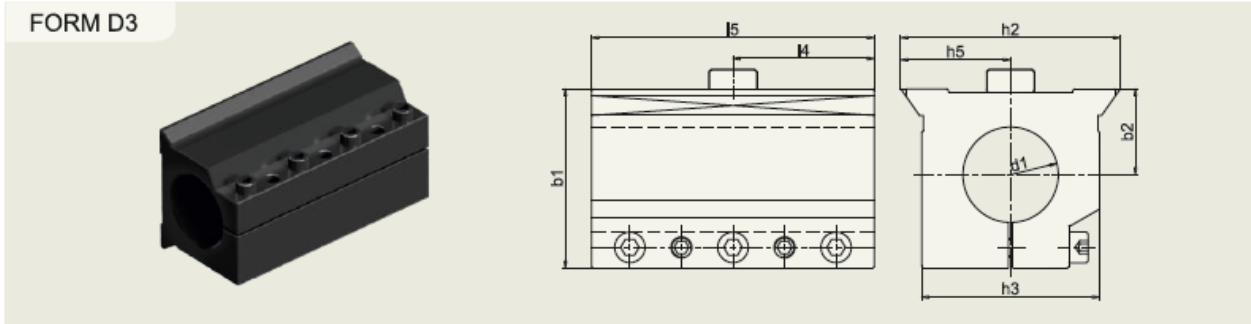

CODE	h2	d1	b1	b2	h3	h5	l4	l5		
VBTH-D3 72 40	72	40	76	35	±0.02	72	36	±0.02	75	150
VBTH-D3 72 50	72	50	80	40		72	36		75	150
VBTH-D3 90 50	90	50	94	45	±0.04	90	45	±0.04	99	198
VBTH-D3 90 60	90	60	100	50		90	45		99	198
VBTH-D3 115 50	115	50	94	45		93	57.5		99	198
VBTH-D3 115 60	115	60	100	50		93	57.5		99	198
VBTH-D3 115 80	115	80	120	60		115	57.5		99	198
VBTH-D3 140 60	140	60	110	60		115	70		99	198
VBTH-D3 140 80	140	80	125	60		115	70		119	238
VBTH-D3 140 100	140	100	145	70		140	70		119	238

VERTICAL - RADIAL AND AXIAL TOOL HOLDER - LEFT HAND

SX

FORM-L

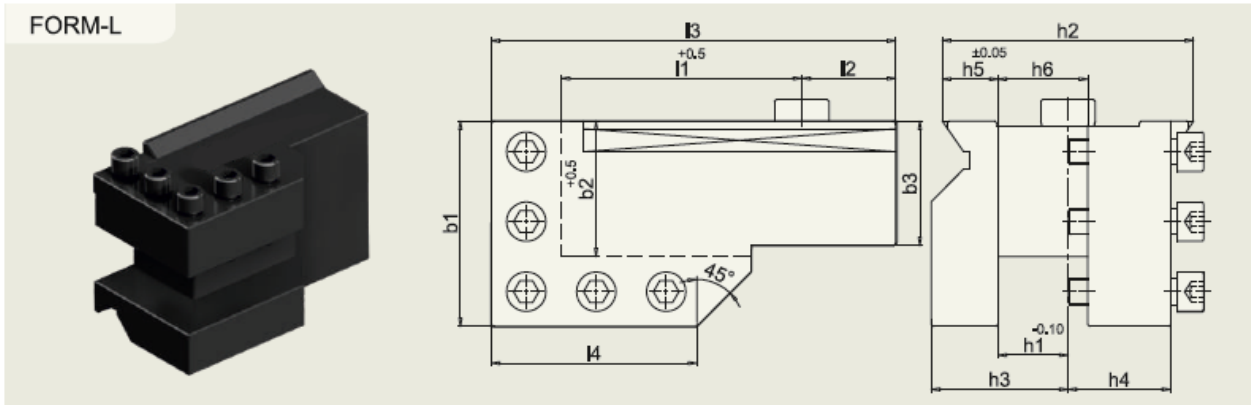

CODE	h2	h1	b1	b2	b3	h3	h4	h5	h6	l1	l2	l3	l4
VRATH-L 72 25	72	25	63	41	36	43	26	16	29	51	29	102	63
VRATH-L 90 25	90	25	80	55	50	50	35	20	34	74	39	138	80
VRATH-L 115 32	115	32	94	62	57	62	45	25.5	41	110	43	185	94
VRATH-L 140 40	140	40	110	70	65	80	57	30	53	110	59	209	110

Omap Tools di Frosinini Daniele & C sas

SEDE LEGALE: Via Montecarlo, 31 52027 S.GIOVANNI VALDARNO (AR) ITALY

SEDE OPERATIVA: Lungarno G. Reni, 38 52027 S.GIOVANNI VALDARNO (AR) ITALY - P.IVA – COD. FISC. 02307160511
ph 0039 055 8349026

info@omaptools.com

www.omaptools.it

INTEHNIKA.RU

FORM - R

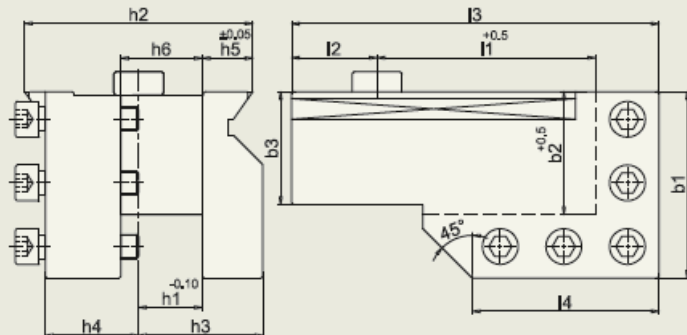

CODE	h2	h1	b1	b2	b3	h3	h4	h5	h6	l1	l2	l3	l4
VRATH-R 72 25	72	25	63	41	36	43	26	16	29	51	29	102	63
VRATH-R 90 25	90	25	80	55	50	50	35	20	34	74	39	138	80
VRATH-R 115 32	115	32	94	62	57	62	45	25.5	41	110	43	185	94
VRATH-R 140 40	140	40	110	70	65	80	57	30	53	110	59	209	110

Omap Tools di Frosinini Daniele & C sas

SEDE LEGALE: Via Montecarlo, 31 52027 S.GIOVANNI VALDARNO (AR) ITALY

SEDE OPERATIVA: Lungarno G. Reni, 38 52027 S.GIOVANNI VALDARNO (AR) ITALY - P.IVA – COD. FISC. 02307160511
ph 0039 055 8349026

info@omaptools.com

www.omaptools.it

INTEHNIKA.RU



OMAP TOOLS sas

Lungarno G. Reni, 38
52027 San Giovanni Valdarno (Ar)
Italy

CONTATTI - CONTACT

T. 0039 055 8349026
info@omaptools.com
[www@omaptools.com](http://www.omaptools.com)