

DOMX[®]

The revolution on HRSA Turning



DOMX

NEW

PHH
NEW
GRADE

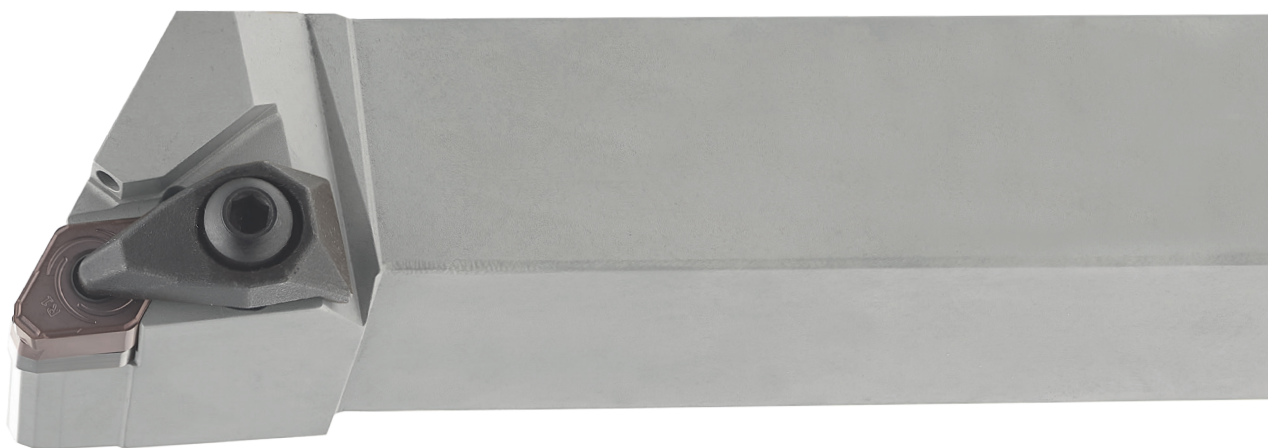

DOMX[®]

SINCE 1916

A revolução em torneamento de materiais termorresistentes | La revolución en el torneado de materiales exóticos

Designed especially for HRSA, the new DOMX[®] combined with the latest PHH technology, offers exceptional performance in exotic materials machining. When your material has high Ni or Co content DOMX[®] is the choice!

- First choice for **HRSA** medium to rough turning;
- 4 positive cutting edges on double sided negative insert.**

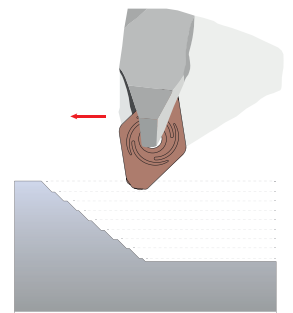

- Machine at 45° with a 93° holder;
- Up to +140% tool life improvement.**

PHH GRADE | Grau PHH | Grado PHH

Product of the latest coating technology, the new PHH coating comes to revolutionize the turning of HRSA. PHH is a stable PVD coating that merges both high hardness and unmatched heat resistance.







First choice for HRSA.

Solution for general turning of HRSA.



	1	5	10	15	20	25	30	
S HEAT RESISTANT / TITANIUM ALLOYS			PHH910	PHH910	PHH910	PHH910	PHH910	PVD
				PHH920	PHH920	PHH920	PHH920	PVD

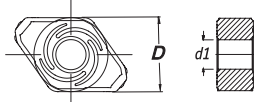

Inserts Pastilhas Plaquetas	(1) Geometry code	(2) Grade code	S		Dimensions (mm) Dimensões (mm) Dimensiones (mm)				Cutting Conditions Condições de Corte Condiciones de Corte					Technical drawing Desenho técnico Dibujo técnico	
			PVD		D	S	Re	d1	ap (mm)	Min	Max	fn (mm/rev)	Min		Max
			X6	Y3											
	1124595	DOMX 1506R1-GS			12,70	6,35	0,80	5,16	1,50	0,20	2,00	0,30	0,20	0,50	
	1124493	DOMX 1506L1-GS			12,70	6,35	0,80	5,16	1,50	0,20	2,00	0,30	0,20	0,50	

 First choice | 1ª Escolha | 1ª Opción  Stock items | Itens de stock  Available under request | Disponível sob consulta | Disponible bajo consulta

Insert Order Code: (1) Geometry code + (2) Grade code

A = DDJN-DX1 45° | TOOLHOLDERS

(D) DIMPLE LOCK TOOLHOLDERS

Roughing to Heavy Roughing	Roughing to Heavy Roughing
DOMX (L1)	DOMX (R1)
	
(15)	(15)

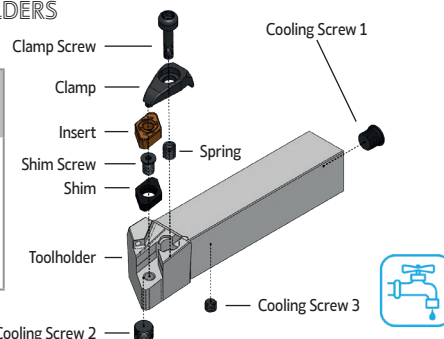



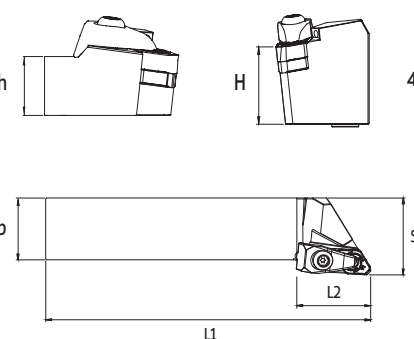

Clamp Screw
Clamp
Insert
Shim Screw
Shim
Toolholder
Cooling Screw 1
Cooling Screw 2
Cooling Screw 3
Spring

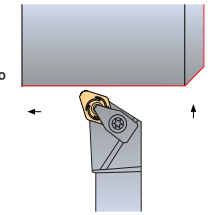

h
H
45°
b
L1
L2
S













Axial: -6,25°
Radial: -6,75°

Order Code		Reference	Dimensions (mm)					Insert	Kg	Stock	
R	L		H-h	b	L1	L2	S			R	L
182000900	182001200	DDJN R/L 2020 K15-A-DX1	20	20	125	42	25	DOMX 1506..	0,40		
182001000	182001300	DDJN R/L 2525 M15-A-DX1	25	25	150	42	32	DOMX 1506..	0,75		
182001100	182001400	DDJN R/L 3232 P15-A-DX1	32	32	170	42	40	DOMX 1506..	1,30		

 Stock item | Produto de stock | Itens de stock  Available under request | Disponível sobre consulta | Disponible bajo consulta



SPARE PARTS | Complementos | Repuestos

Cutter Reference	Shim R	Shim L	Shim Screw	Spring	Clamp	Clamp Screw	Wrench	Coolant Screw 1	Coolant Screw 2	Coolant Screw 3
DDJN R/L 2020 K15-A-DX1										
DDJN R/L 2020 K15-A-DX1	CD150503	CD150502	T06010000	M09513	GA07002	D0602900	SS40	H0600475	H1000875	T1000875
DDJN R/L 2525 M15-A-DX1	CD150503	CD150502	T06010000	M09513	GA07002	D0602900	SS40	H0600475	H1000875	T1000875
DDJN R/L 3232 P15-A-DX1	CD150503	CD150502	T06010000	M09513	GA07002	D0602900	SS40	-	H1000875	-







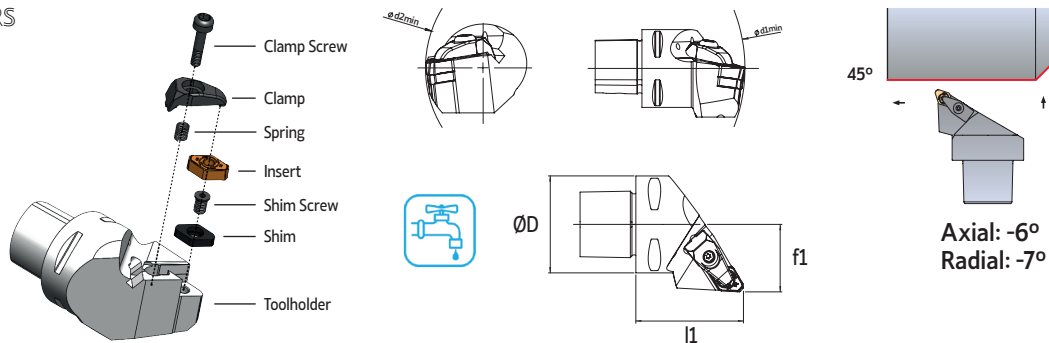

A = DDJN-DX1 45° || TOOLHOLDERS

NEW

(D) DIMPLE LOCK TOOLHOLDERS

Roughing to Heavy Roughing	Roughing to Heavy Roughing
DOMX (L1)	DOMX (R1)
	
(15)	(15)









Order Code		Reference	Dimensions (mm)					Insert	Kg	Stock	
R	L		ØD	Ød1 min	Ød2 min	f1	l1			R	L
182000100	182000500	PSC40-DDJNR/L27055-15-DX1	40	110	145	27	55	DOMX 1506..	0,42		
182000200	182000600	PSC50-DDJNR/L35060-15-DX1	50	110	165	35	60	DOMX 1506..	0,80		
182000300	182000700	PSC63-DDJNR/L45065-15-DX1	63	110	190	45	65	DOMX 1506..	1,10		
182000400	182000800	PSC80-DDJNR/L55080-15-DX1	80	110	250	55	80	DOMX 1506..	2,74		

 Stock item | Produto de stock | Itens de stock

 Available under request | Disponível sobre consulta | Disponible bajo consulta

SPARE PARTS || Complementos | Repuestos

Cutter Reference	Shim R	Shim L	Shim Screw	Spring	Clamp	Clamp Screw	Wrench
PSC40-DDJNR/L27055-15-DX1							
PSC50-DDJNR/L35060-15-DX1	CD150503	CD150502	T06010000	M09513	GA07002	D0602900	SS40
PSC63-DDJNR/L45065-15-DX1	CD150503	CD150502	T06010000	M09513	GA07002	D0602900	SS40
PSC80-DDJNR/L55080-15-DX1	CD150503	CD150502	T06010000	M09513	GA07002	D0602900	SS40

Note: It is possible to adapt your standard toolholder | É possível adaptar um suporte convencional | Puede adaptar un soporte convencional

HEADQUARTERS

PALBIT. S.A.

P.O.Box 4 - Palhal

3854-908 - Branca ALB - Portugal

T (+351) 234 540 300 | F (+351) 234 540 301

palbit@palbit.pt | www.palbit.pt

Branch office:

PALBIT México

Emerson 150. Int.803-804. Colonia Chapultepec

Morales Delagación Miguel Hidalgo

C.P. 11570 México DF

T (+52) 5555 454 543 | F (+52) 5552 509 190

info@palbit.com.mx | www.palbit.com.mx

